

# DAVCRON ENGINEERING



**THE DAVCRON AGITATOR MUST BE OPERATED BY  
TRAINED AND AUTHORISED PERSONNEL ONLY**

## DAVCRON ENGINEERING PTY LTD

General Engineering & Maintenance Contractors - Inc. NSW

**SYDNEY**  
(Head Office & Factory)  
5 Tennyson Street  
GRANVILLE NSW 2142  
Tel: 02 9637 8186  
Fax: 02 9637 5164

**GOSFORD**  
Factory / Workshop  
22 Justrute Drive  
GOSFORD NSW 2250  
Tel: 02 4324 1415  
Fax: 02 4322 0360

Email: [office@davcron.com.au](mailto:office@davcron.com.au)  
Web: [www.davcron.com.au](http://www.davcron.com.au)



Quality  
Endorsed  
Company

# 915 Mhz Electronic Mixer Controls Operations Manual

## INDEX

<b>1.0</b>	<b>ELECTRONIC CONTROL UNIT</b>	
1.1	Unit Overview	1
1.2	GPS Tracking	1
1.3	Hard Wired Unit in Cabin	1
1.4	Summary of Control Panel	1-3
<b>2.0</b>	<b>OPERATION</b>	
2.0	How to use the Cabin Controller	3-4
<b>3.0</b>	<b>PROGRAMMING</b>	
3.0	To Program the Transmitter	5
<b>4.0</b>	<b>OVERRIDE</b>	
4.0	Manual Override Switch	5
<b>5.0</b>	<b>REAR STOP SWITCH</b>	
5.0	Rear Stop/Resume Switch	6
<b>5.0</b>	<b>TROUBLESHOOTING</b>	
5.0	Drum not Turning at All	7
5.1	Drum not Turning in Discharge	8
5.2	No Throttle Operation	9
5.3	Wiring Diagram	10-11

## 1.0 ELECTRONIC CONTROL UNIT

### 1.1 UNIT OVERVIEW

The Davcron Concrete Agitator is fitted and supplied with an electronic control unit as well as having hard wired control buttons for mix/discharge and chute raising and lowering functions.

The electronic control unit is a 915 Mhz Electric Controller is made up of two (2) components which are the hard wired cabin keypad and the remote keypad which is linked to the unit via individual transmitting protocols (it is programmed to your truck only).

The unit operate on 915Mhz and has been designed for ease of operation during charging, discharging, cleaning, general use and emergency operation.

After reading the instructions including the troubleshooting section of this manual should you have any queries please call Davcron Engineering on 02 9637 8186



### 1.2 GPS TRACKING

**(Optional - if fitted to your unit)**

The Electronic Control Unit has the operational outputs for GPS tracking of your mixer when in the 3G network.

### 1.3 HARD WIRED UNIT IN CABIN

Your cabin unit is fitted with a hard wired unit that transmits to the remote hand held unit that can be used outside the cabin. (Please see opposite)

### 1.4 Summary of the panel of Davcron 5 STAR Control Panel

#### No.1 - POWER LIGHT

Power LED indicates power supply is active to control unit.

#### No.2 - RESUME BUTTON

Use this button to resume your barrel speed back to your preset rpm.

#### No.3 - STOP BUTTON

Use this button to stop the rotation of the barrel in any mode. MIX, DISCHARGE and TRANSIT.

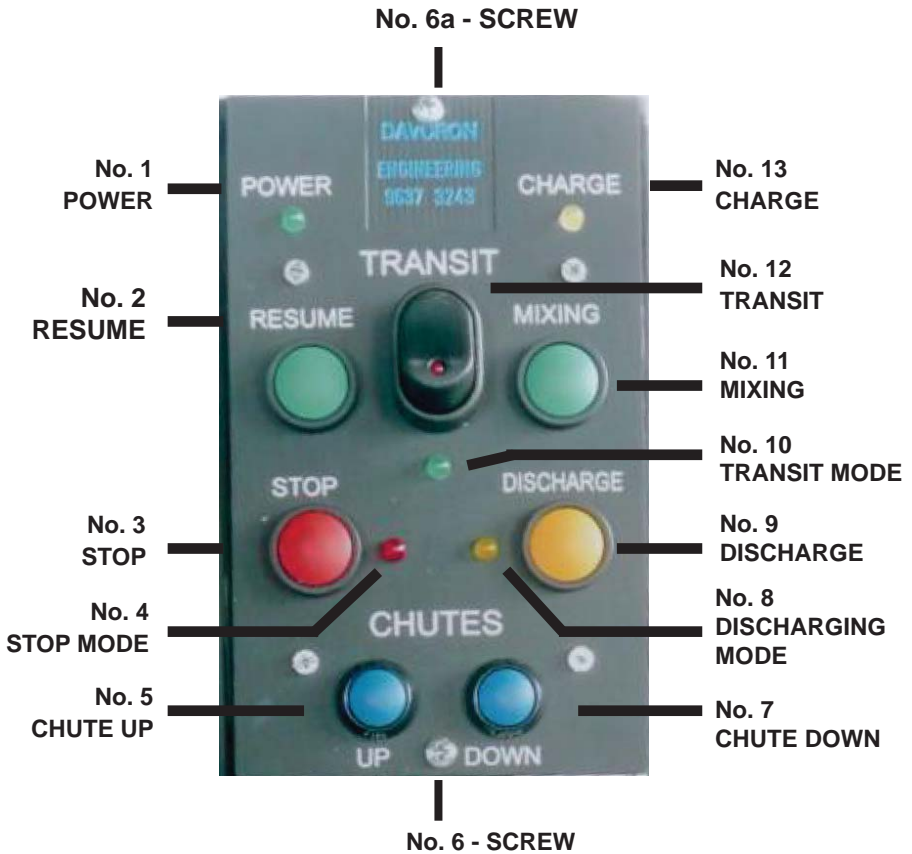

**No.4 - STOP MODE LIGHT**

When the barrel rotation is stopped this red light will flash continuously.

**No.5 - CHUTE UP BUTTON**

Use this button to power the chute up via the hydraulic ram.

**No.6/6a - UNIT SCREWS**

Screws to remove panel for programming,.

**No.7 - CHUTE DOWN BUTTON**

Use this button to power the chute down via the hydraulic ram.

**No.8 - DISCHARGING MODE LIGHT**

When the barrel is discharging this yellow light will flash continuously.

### **No.9 - DISCHARGE INCREASE AND MIX DECREASE BUTTON**

Use this button to increase the rpm of the barrel when discharging and also use this button to decrease the barrel rpm when mixing.

### **No.10 - TRANSIT MODE LIGHT**

When in transit and mixing is underway at the preset rpm of the barrel this light will indicate constant green.

### **No.11 - MIXING BUTTON**

Use this button to increase the rpm of the barrel when mixing and also use this button to decrease the rpm of the barrel when discharging.

### **No.12 - TRANSIT SWITCH**

Use this switch for transporting concrete that will set the barrel speed in the preset rpm for transit. This will also engage a protection protocol against any discharge.

Engage the transit mode when the truck is in transit to job site. The RPM is preset at 1.5rpm when this mode is engaged. PLEASE NOTE: The Transit Mode has a protection protocol program to prevent against the unit going into discharge mode.

The drum speed can be increased while in transit mode by pressing the mix button.

To return to the transit mode rpm, switch the transit switch off and then on again to engage.

### **No.13 - REMOTE CHARGE LIGHT**

This light indicates:            RED = CHARGE MODE  
   GREEN = FULLY CHARGED

## **2.0 HOW TO USE CABIN CONTROLLER**

### **To start MIXING MODE from zero rotation:**

Press the mix button and hold until required barrel speed is reached

Once mixed and you want to decrease the barrel speed press the DISCHARGE BUTTON until the desired rpm is reached.

### **To STOP and RESUME barrel rotation:**

To STOP barrel rotation, press the red STOP button, while in the stopped position the stop mode red light will flash.

To resume barrel rotation, press the green RESUME button, mixing or discharge will then resume.

**To start DISCHARGE MODE from zero barrel rotation:**

Press and hold the discharge button until the required speed is reached.

To decrease the barrel speed in discharge press the mix button until the desired rpm is reached.

While in DISCHARGE MODE the yellow light will flash.

**TRANSIT MIXING operation:**

While in transit mixing mode the green light will flash.

Transit mixing speed can be increased by pressing the MIX button and then can be returned only to the transit preset speed by pressing the discharge button.

PLEASE NOTE: When in transit mode discharge is LOCKED by all button operation.

**OVERALL**

All operations can be changed while in the STOP MODE.

If in MIX or DISCHARGE MODE and the TRANSIT button is selected both will cancel and the unit will return to TRANSIT operation rpm.

**NOTE:** When changing barrel direction the button, either the MIX button (if going from discharge to mix), or the DISCHARGE button (if going from mix to discharge) has to be repressed after the barrel has stopped so that the selection direction is the direct action of the operator.

### 3.0 TO PROGRAM THE TRANSMITTER

To programme the transmitter to the remote receiver:

Firstly remove the two screws [6 and 6a] - See page 3 for diagram.  
Remove cable tie from bottom of the control unit.  
Fold the front panel forward.

Then follow these steps:

- The receiver card is on the rear of the front panel of the control unit.
- There are 12 'dip' switches located on this card
- On the transmitter once the front cover is removed you will also find 12 'dip' switches on this card.

**IMPORTANT:** To remove the front touch pad you must undo the two screws on the top rear of the remote and the screws under the battery cover only - **DO NOT UNDO THE CHARGE SCREWS OR DAMAGE WILL OCCUR TO THE TRANSMITTER.**

- To program the remote to the receiver simply ensure that the 'dip' switches on each card match, by doing this you are allowing them to communicate to each other.
- If you want to change the code of your remote, simply do so, but ensure that the 'dip' match your receiver.
- Replace covers and screws.

Your programming should now be complete and the unit working.

### 4.0 MANUAL OVERRIDE SWITCH

in the case of an emergency you can override the mixer drive pump manually.

**PLEASE NOTE:**  
The colour of the toggle will always be the same colour as the pump.

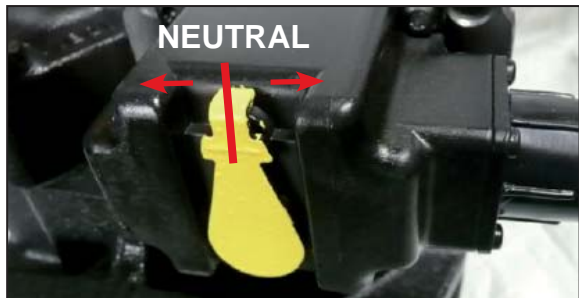

## 5.0 REAR STOP RESUME SWITCH

The mixer unit has a STOP and RESUME switch hard wired to the mixer control box. This switch is located on the drivers side at the rear of the truck.

The switch is identified by a yellow box and has a large red button and is IP 65 Rated.

Operation of the switch from time-to-time will ensure working order and maintain free movement.

- To STOP the mixer barrel movement - push the red button.
- To RESUME operation - turn the red button ANTI-CLOCKWISE and release

**NOTE:** All controls (mixing, discharging, transit) from the cabin control or transmitter will not operate until the anti-clockwise rotation and release of the button is complete.

The barrel direction and speed will need to be reset after using the emergency stop button.





6.0

**TROUBLESHOOTING - DRUM NOT TURNING AT ALL**

Below is from control box in truck cabin.

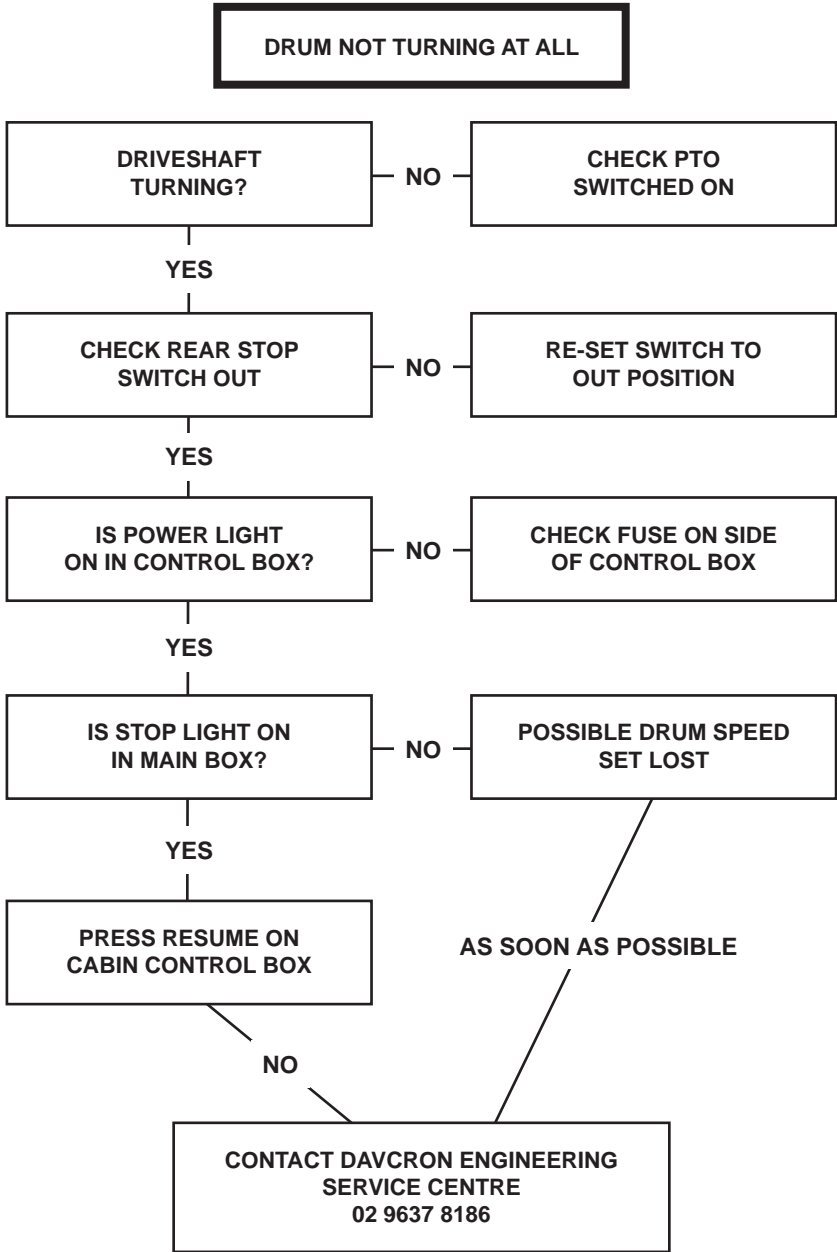

**6.1 TROUBLESHOOTING - DRUM NOT TURNING IN DISCHARGE**

Below is from control box in truck cabin.

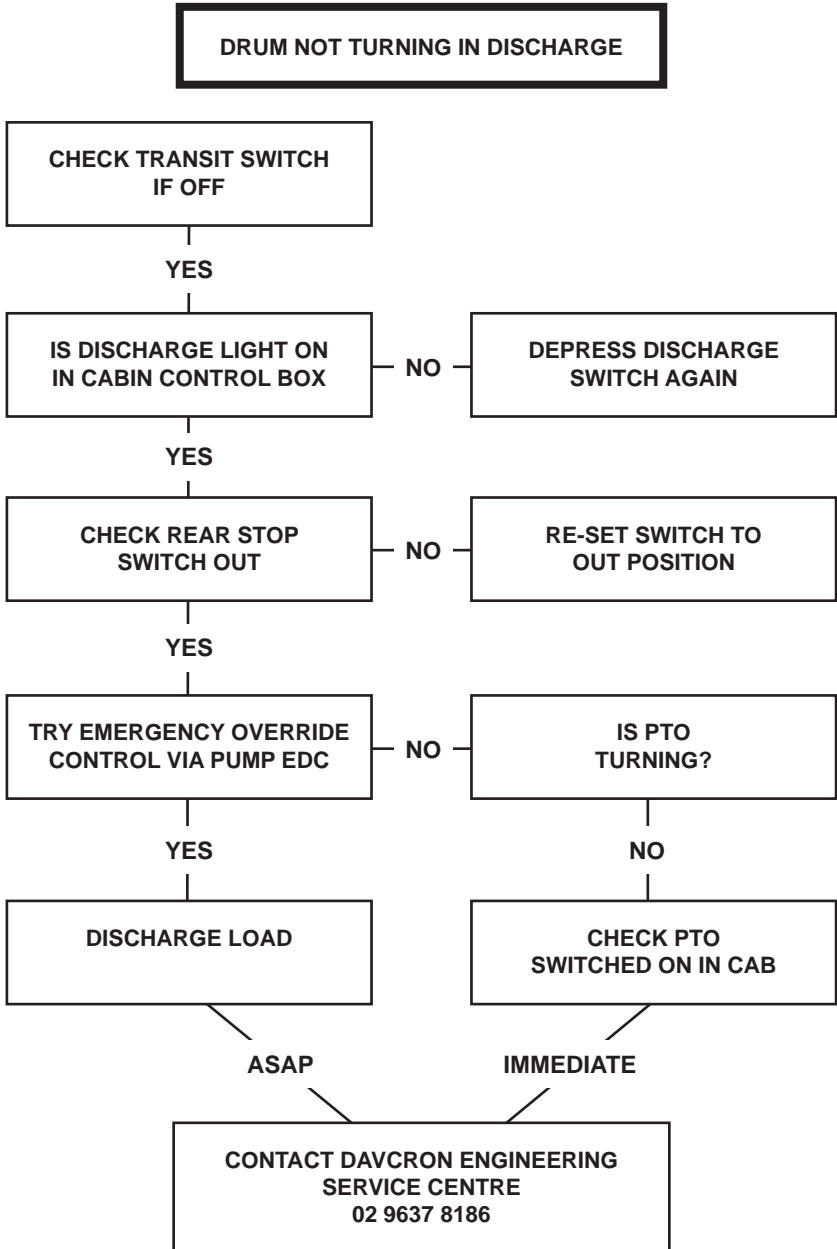

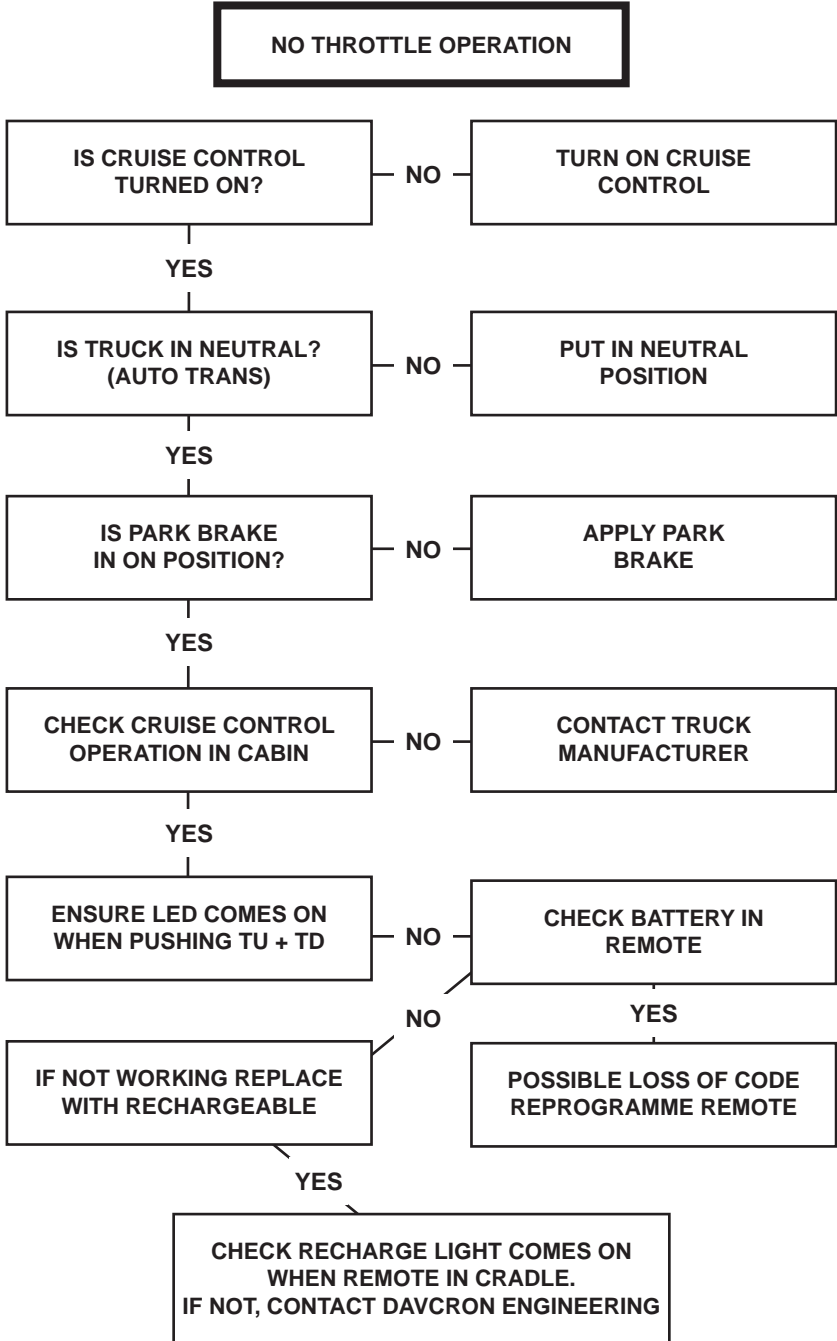

# DAVCRON ENGINEERING



REAR  
CHUTE  
SWITCH

IGNITION

**FEMALE PLUG**

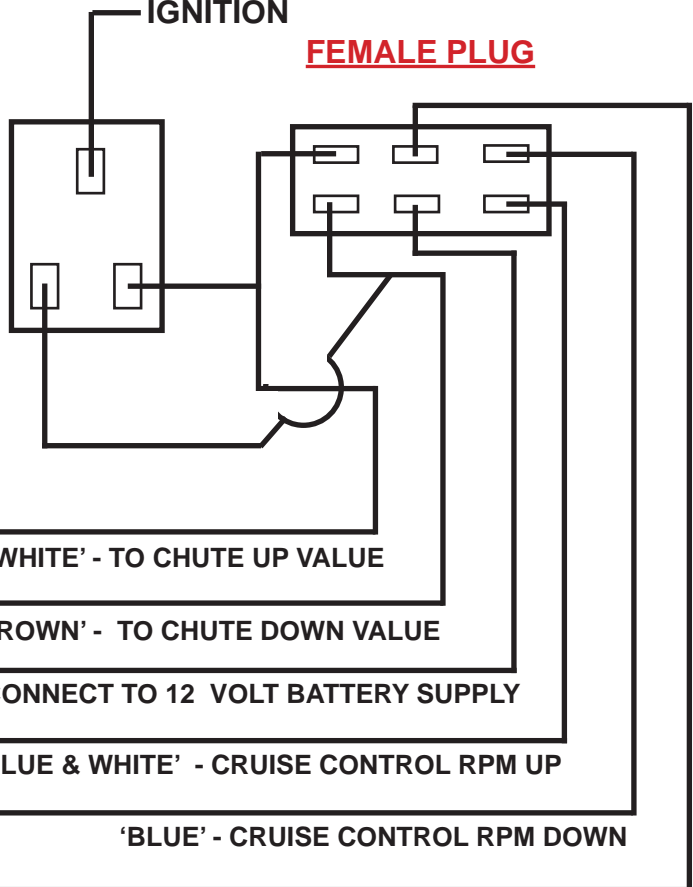

'BROWN & WHITE' - TO CHUTE UP VALUE

'BROWN' - TO CHUTE DOWN VALUE

'RED & WHITE' - CONNECT TO 12 VOLT BATTERY SUPPLY

'BLUE & WHITE' - CRUISE CONTROL RPM UP

'BLUE' - CRUISE CONTROL RPM DOWN

'ORANGE' - CRUISE CONTROL 'COMMON FEED'  
**NB:** Please refer to truck specifications

**ELECTRONIC CONTROL SYSTEM**  
**915 MHz**

Wiring Diagram (September 2012)

**MALE PLUG**

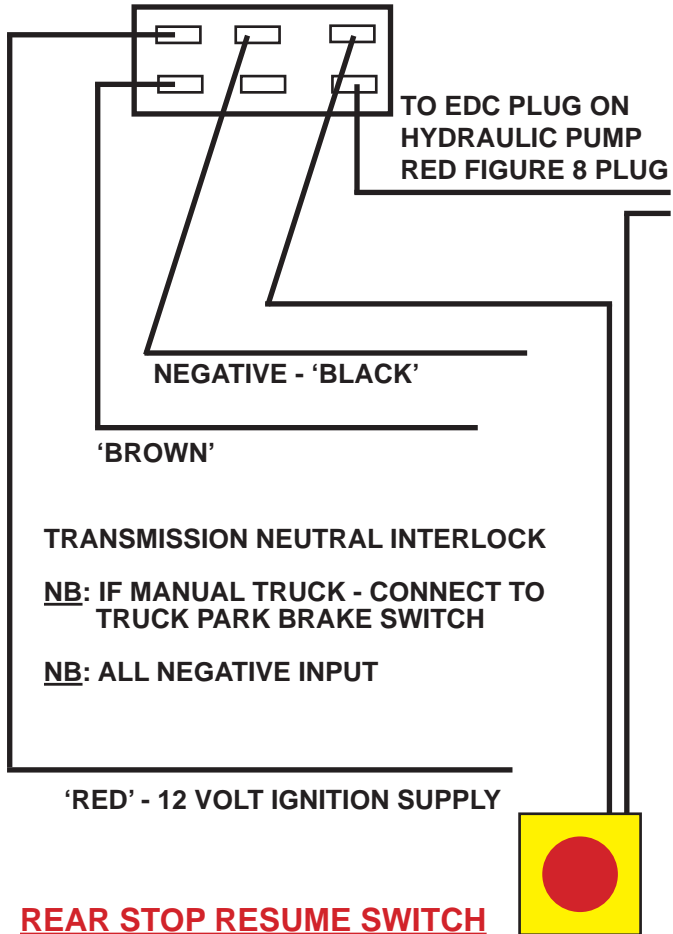



# **DAVCRON ENGINEERING PTY LTD**

General Engineering & Maintenance Contractors - Inc. NSW

## **SYDNEY**

**(Head Office & Factory)**

5 Tennyson Street

GRANVILLE NSW 2142

**Tel:** 02 9637 8186

**Fax:** 02 9637 5164

## **GOSFORD**

**Factory / Workshop**

22 Justrute Drive

GOSFORD NSW 2250

**Tel:** 02 4324 1415

**Fax:** 02 4322 0360

**Email:** [office@davcron.com.au](mailto:office@davcron.com.au)

**Web:** [www.davcron.com.au](http://www.davcron.com.au)